

### TECHNICAL SPECIFICATIONS

**Materials of Construction (wetted parts):** Polypropylene, EPDM  
**Temperature Limits:** .....30° - 120°F (-1.1° - 49°C)  
**Weight:** .....3.3 oz.  
**Dimensions:** .....5 3/16" H x 4 13/16" W x 2 3/8" D  
**Approvals:** .....NSF listed

### APPLICATION INFORMATION

Flojet's G56 Flow Reversal Valve (FRV) is designed as an add-on accessory for the G56 Beer Pump to allow beer line cleaners to run cleaning solution through a Flojet G56 pump driven beer system in both directions. Running cleaning solution through draught beer systems in alternating directions from the faucet to the tapping device (and vice versa) has been found to enhance cleaning efficiency. Further, a multiple beer faucet system utilizing G56 beer pumps with Flow Reversal Valves allows for multiple lines to be cleaned at one time. This can be done by connecting keg taps with double flushers and connecting faucets with cleaning jumpers (see Line Cleaning Diagram).

### TYPICAL INSTALLATION

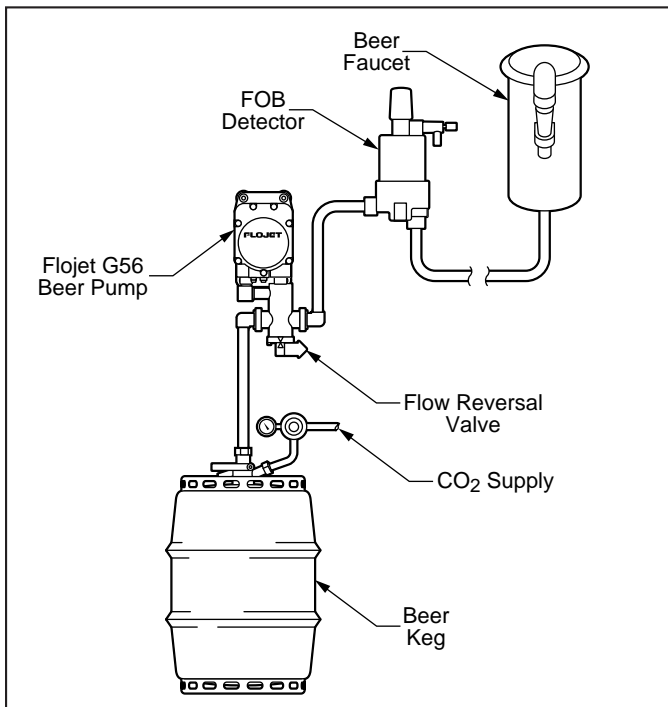

### ASSEMBLY TO G56 PUMP

1. Slide port clips back against base of pump.
2. Insure that both O-rings of the FRV are adequately lubricated.
3. Slide FRV ports into pump and secure with clips (see Assembly Drawing).
4. Attach inlet tubing from keg to the left side port fitting and secure with Oetiker Clamp (clamps not provided).
5. Attach discharge tubing to the right side port fitting and secure with Oetiker Clamp.
6. Install air inlet and exhaust ports to pump.

### ASSEMBLY DIAGRAM

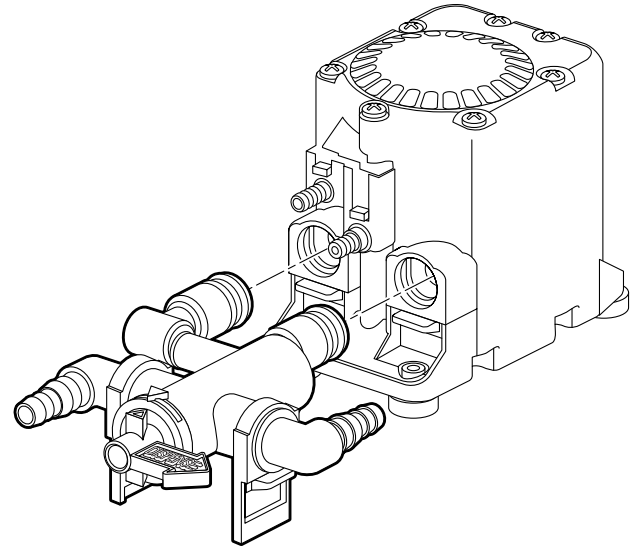

Model G56 Flow Reversal Valve

### MOUNTING

- Pump must be located within 10 ft. (1.83 m) above or below the keg or cask.
- Pump ports must be facing down to maximize pump performance.
- Mounting grommets are part of pump assembly and add stability.
- Fasten pump securely to wall or rack.
- If using a FOB device, mount it slightly above and directly after the discharge of the pump. Caution: If a FOB is not used, the pump will continue to cycle after the keg has run dry.

### DIMENSIONAL DRAWING

Inches (Millimeters)  
 Dimensional tolerances  
 ± 0.06 inches

Consult factory if precise  
 details are required.

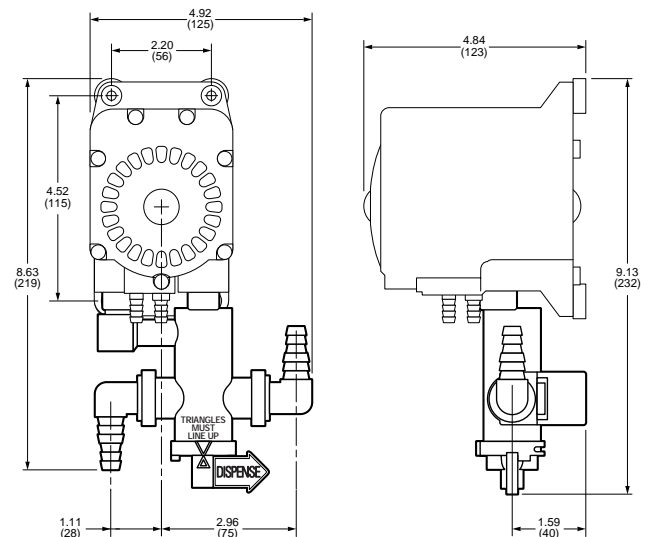

## PUMP/LINE CLEANING OPERATION

For operation of the pump, please see G56 Beer Pump Installation Instructions (form #81000-303). For normal dispensing, if a Flow Reversal Valve is added to the pump, the set-up would be as shown in the Typical Installation Drawing. Note that the valve is in the "Dispense Position" (see Valve Positions Drawing).

### For cleaning one line from the faucet to the keg tap:

1. Turn the valve to the "Reverse Flow" position.
2. Attach a cleaning jumper to the faucet.
3. Set FOB to bypass mode.
4. Pump the cleaning solution from the faucet to the keg tap.
5. Be sure to rinse system with cold, clean rinse water.
6. After cleaning and rinsing system, return all valves to normal operating (Dispense) positions.

### For cleaning multiple lines:

1. Attach a cleaning jumper to the first faucet.
2. Turn the valve to the "Reverse Flow" position.
3. Connect the keg tap from the first line to the keg tap of the second line with a double flusher.
4. Leave the valve on the second pump in the "Dispense Position."
5. Connect the second faucet to the third faucet with a cleaning jumper.
6. Repeat steps 2 through 5.
7. Set all FOBs to bypass mode.
8. Circulate cleaning solution through system.
9. Be sure to rinse system with cold, clean rinse water.
10. After cleaning and rinsing system, return all valves to normal operating (Dispense) positions.

**CAUTION: Do not close the system while running the cleaning pumps. Excessive pressure build-up could damage pumps.**

## LINE CLEANING DIAGRAM

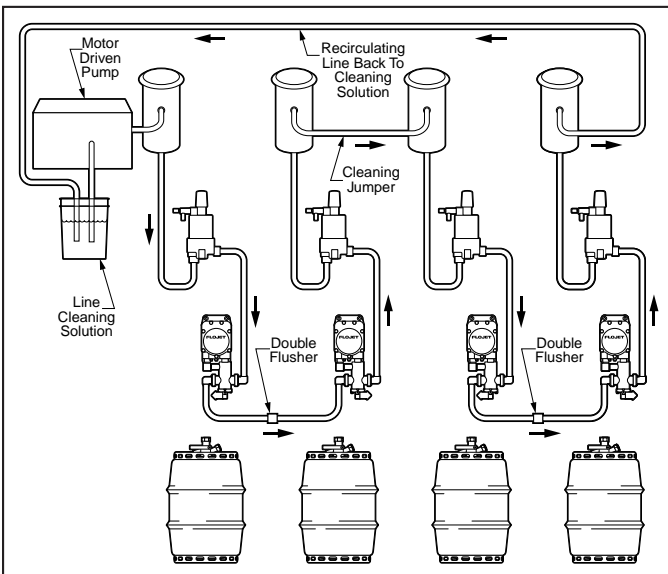

## VALVE POSITIONS

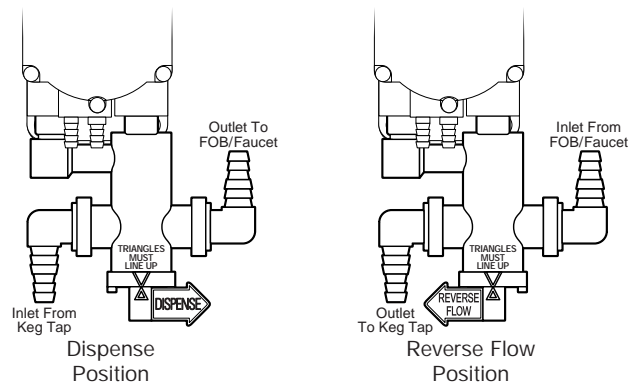

## HOSE CONNECTIONS

- All fittings are quick change.
- Secure with appropriate Oetiker Clamp for specified tubing size or worm gear clamp 360 degree uniform clamping band.
- It is advisable to secure all hoses to prevent excessive movement.

## AVAILABLE PORT FITTINGS

- Standard Fitting: 3/8" - 1/2" (10mm - 13mm) Barb, plastic, elbow
- Optional Fittings:
  - 1/4" (6.35 mm) Barb, stainless steel, straight
  - 3/8" (9.52 mm) Barb, stainless steel, straight
  - 3/8" - 1/2" (10 mm - 13 mm) Barb, plastic, straight
  - 1/2" (13 mm) Barb, plastic, straight
  - 1/2" (13 mm) Barb, plastic, elbow

## FLOW CURVE

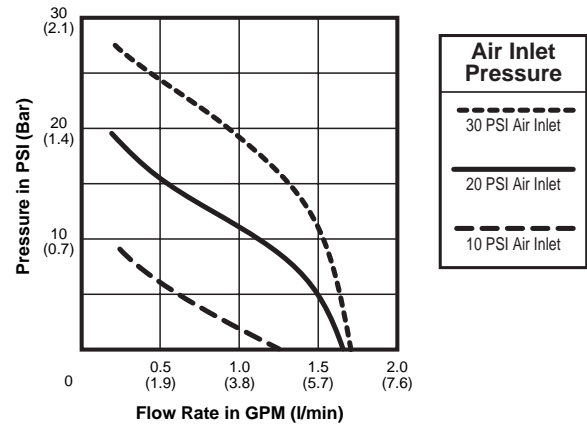

## PRODUCT WARRANTY

Flojet warrants this product to be free of defects in material and/or workmanship for a period of one year after purchase by the customer from Flojet. During this one year warranty period, Flojet will at its option, at no charge to the customer, repair or replace this product, if found defective, with a new or reconditioned product, but not to include costs of removal or installation. No product will be accepted for return without a return material authorization number. All return goods must be shipped with transportation charges prepaid. This is only a summary of our Limited Warranty. For a copy of our complete warranty, please request Form No. 100-101.

## RETURN PROCEDURE

Prior to returning any product to Flojet, call customer service for an authorization number. This number must be written on the outside of the shipping package. Place a note inside the package with an explanation for return as well as the authorization number. Include your name, address and phone number.

Flojet



**ITT Industries**  
Engineered for life

U.S.A.  
Flojet  
20 Icon  
Foothill Ranch, CA 92610-3000  
Tel: (949) 859-4945  
Fax: (949) 859-1153

UNITED KINGDOM  
Flojet, Unit 1, Avant Business Centre  
Denbigh West Industrial Estate  
Milton Keynes, Bucks, England MK1 1DL  
Tel: 44 1908 370088  
Fax: 44 1908 373731