

VINSERVICE®



ITALY

OPERATION AND MAINTENANCE BOOK

FLAT - SUPER FLAT

Glycol with Digital Thermostat

Document Code: **0150MANFLEN.000**

serial number:



PREAMBLE

The present handbook must be considered as integral part of the equipment, and it must always be available to the persons operating with the unit; this manual must always stay with the equipment, also in case the unit is transferred to another owner.

The operators must carefully read this handbook and follow all instructions herein contained, because VINSERVICE will not be liable for any damages occurred to persons and/or things, or suffered by the equipment itself, whenever any conditions here in described are not respected. Customers has the obligation of respecting the industrial trade secret, according which the following literature and its enclosures could not be altered, edited or sold to third parts, without the explicit authorization of VINSERVICE.

TABLES OF CONTENTS

REV10042014

PREAMBLE	1
TABLE OF CONTENTS	2
Alphabetic index	3
Analytical index.....	4
SUPPLY CONDITIONS	5
List of enclosures.....	5
SYMBOLS AND SIGNS	6
AIM OF THE DOCUMENT	7
PERSONNEL QUALITIES	7
REFERENCE STANDARDS	7
FIELD OF EMPLOYMENT	8
Table: Limits of use.....	8
Prohibited uses.....	8
MACHINE DESCRIPTION	9
Identifying machinery and manufacturer.....	10
Technical specifications.....	10
ACCIDENT PREVENTION AND RESIDUAL RISKS	12
LIFTING AND TRANSPORT	14
INSTALLATION	15
Positioning.....	15
Water connection.....	15
Electrical connection.....	15
OPERATION	16
transformer (TR) OPTIONAL.....	16
digital thermostat (TD)	17
TROUBLESHOOTING	18
MAINTENANCE	19
Routine maintenance.....	19
Extraordinary maintenance.....	19
Storing, dismantling and disposal.....	19
DECLARATION OF COMFORMITY.....	22

Alphabetic index of references

Symbols

REV10042014

(B), recirculation pump.....	9, 10, 16, 17
(C), distributor.....	9, 16
(E), tank.....	8, 9, 15, 17, 18
(F), agitator.....	9, 10, 15, 16, 17
(G), probe.....	9, 16, 17
(H), compressor.....	9, 16, 17
(IG), master switch.....	10, 15, 16, 17
(L), condenser.....	8, 9, 18
(M), fan.....	9, 16, 17
(N), capillary tube.....	9
(O), evaporator.....	9, 16
(Q), overflow.....	10, 15, 18
(R), openable panel.....	10, 12, 15
(TD), digital thermostat.....	16
(TR), transformer OPTIONAL.....	9, 16

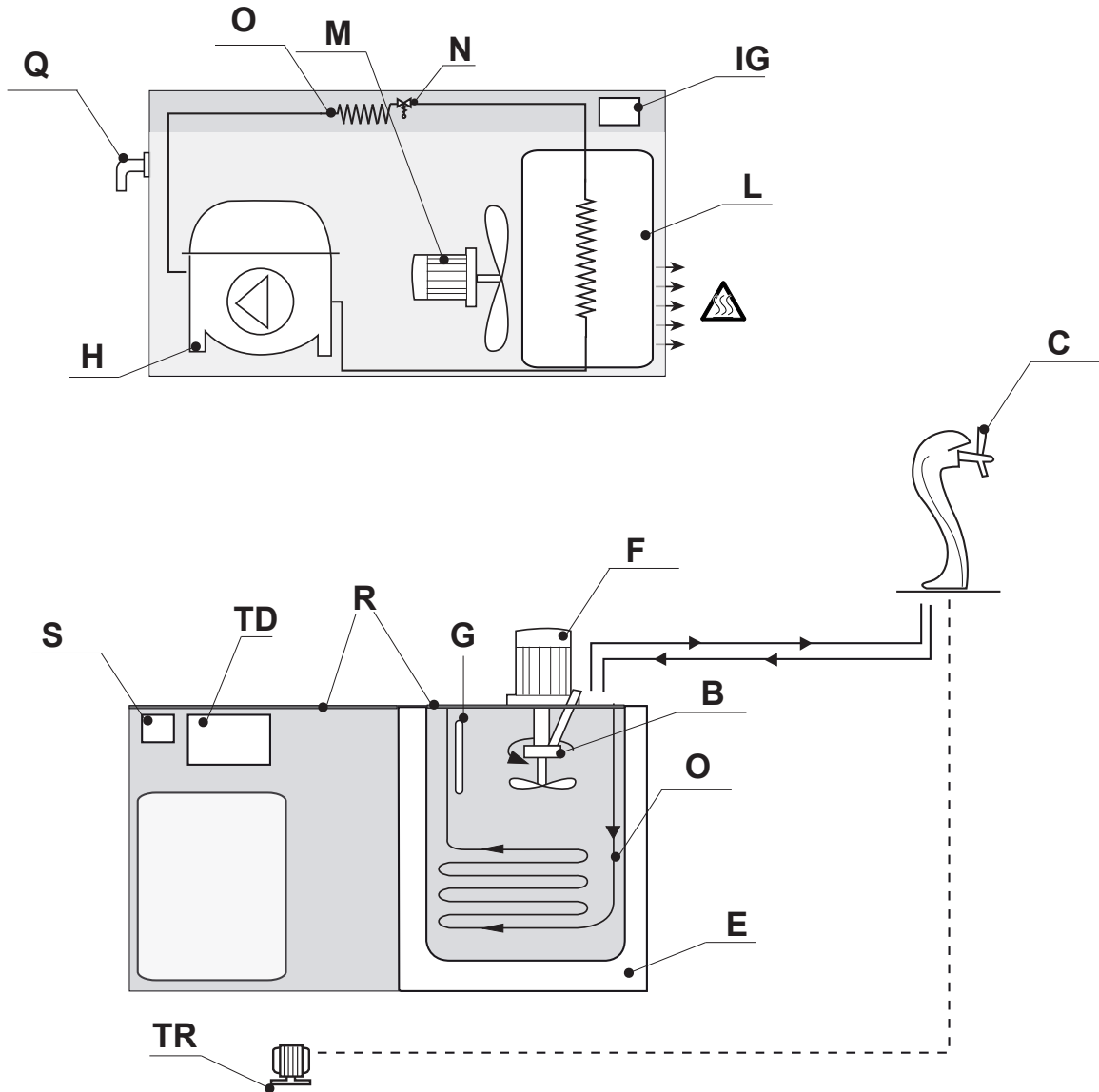

SUPPLY CONDITIONS

VINSERVICE will not be held liable for any failure to comply with the standards governing correct installation.

VINSERVICE will not be held liable for any loss in production, unless expressly shown in the purchase order.

VINSERVICE will not be held liable for any defects or malfunction arising from; improper use of the equipment, alterations due to the transportation or peculiar environmental conditions, lack of or improper maintenance, mishandling or improper service; operation by unqualified personnel and the use of product accessories not belonging to the equipment.

VINSERVICE will not be held liable for damages arising from inappropriate or imprudent operations not conforming to those described within this manual and in the attached documentation performed by both expert and inexperienced personnel.

Since it is not possible to foresee all the installations and environments in which this equipment will be installed, therefore customer must check the following:

- Environmental conditions where the equipment is installed;
- Beverage feeding and pushing systems;
- The capabilities of the personnel entrusted with the installation and/or use of the machine.

The customer must only use original spare parts installed in accordance with their prescribed use.

N.B. Manufacturer accepts liability for commercial parts. If in doubt, ask for documentation.



VINSERVICE will not be held liable for the disposal of equipment parts or materials needed to operate the machine: coolant gas, compressor or pressurised container, condensers, etc... Please remember that this is an electrical equipment and thus its components must be disposed in compliance with the regulations enforced in its country of installation.

List of enclosures

In addition to this operation and maintenance manual the following documents are supplied along with the equipment:

- Declaration of conformity

AIM OF THE DOCUMENT

This document (OPERATION AND MAINTENANCE MANUAL) is a useful guide that enables safe working and the performance of all operations necessary to keep the equipment in a safe working order.

• *The instructions set out in this manual do not replace the safety instructions and technical data on installation and operation of the equipment. It neither replaces common sense nor the safety regulations enforced in the country of installation.*

• **Personnel dealing with the equipment must read this manual carefully;** operators must also be made aware of residual risks arising from its use

PERSONNEL QUALITIES

• Only expert operation or maintenance personnel familiar with the described task and knowledgeable enough to execute them must use this equipment. They must be able to sufficiently carry out the instructions contained in this manual, thoroughly carry out checks and ensure safety.

• The use of unqualified personnel especially for installation and maintenance operations is strictly prohibited.

• Since it is not possible to describe all operational information for the equipment, it is therefore mandatory that persons in operational contact with the equipment possess basic knowledge of its operations in order to perform their duties.

• Personnel in operational contact with the equipment must use the personal protective device required by law: leather gloves for sharpened or pointed objects or components at high temperatures.

REFERENCED STANDARDS

This paragraph shows the International regulations and the National Laws that must be respected in equipment design and manufacture and in the present manual. • D.lgs. n° 81(3April2008) 3 August 2009 N° 103. n.89/391, 89/654, 655/CEE, 89/656, 90/269, 90270, 90/394, 90/679, 93/88/CEE, 95/63/CE, 97/42/CE, 98/24/CE 99/38/CE, 99/92/CE, 2001/45/CE, 2003/10/CE, 2003/18/CE e 2004/40/CE Standards for accident prevention at work; 791(18 October1977) and D.lsg. (25 November1996) n°626 (2006/95/CE) (September 19th, 1994) Implementation of the directives to improve workers' safety and health conditions in their workplaces; 194(6 Novembre 2007) European Community (2004/108/CE) (EMC) Electromagnetic compatibility - 2006/42/CE Machines - 2006/95/CE Electrical equipment of machines CEI EN 60335-2-89: Refrigerating plants CEI EN 60335-2-89/A1/A11 February 2006, CEI EN 60335-2-89/A2 November 2007. UNI EN ISO 12100-1 - UNI EN ISO 12100-2 (EMC) Electromagnetic compatibility - CEI E55014-1: CEI E55014-2: (EMC) Electromagnetic compatibility

FIELD OF EMPLOYMENT

• **VINSERVICE** will not be held liable for damages of any type arising from non compliant or unwise usage. The equipment **MUST** neither be operated by unqualified personnel nor qualified personnel doing so in non compliance with what is described in the present user's manual and attached documentation.



• *The use of this equipment for other purposes rather than those of which it were designed is strictly prohibited.*

This equipment has been designed to cool beverages and food liquids, with the possibilities and features described herein.

Table: Limits of use

- Allowed room temperature: + 5 ÷ + 42 °C;
- Max. allowable operating temperature: 7 bar
- Do not use liquids or beverages with high volatility or flammability degree or that can cause fire;
- Protection degree IP65 and Insulation Class 1.

Prohibited uses

It is strictly prohibited to:

- Use the equipment or parts of it in flammable environments. The equipment cannot be operated or installed in environments where gases or explosive volatile substances are present.

N.B VINSERVICE will not be held liable for unsuitable and/or unhygienic conditions in the workplace.



- **VINSERVICE** will not be held liable for damages of any type arising from non compliant or unwise usage.
- Distribution of beverages without prior cleaning and sanitizing of equipment is strictly prohibited.
- The use of this equipment or part of it for other purposes other than those for which it is designed or not compliant with its proper usage is strictly prohibited. For example;
Do not dry or hang clothes on the condenser grill (H). It is dangerous and can jeopardize the correct operation of the machine.
Do not introduce foreign bodies (bottles or can) into the tank (C) or on the ice bank.

MACHINE DESCRIPTION

- The cooler **VINSERVICE** belonging to glycol line allows the temperature of the liquid recirculating in the system to lower. As a result the temperature of the dispensing body (C) will also lower and will cause either a condensation or ice effect on the body surface.
- The temperature of the recirculation liquid (monopropylenic glycol) is controlled by a digital thermostat (TD) that constantly keeps the temperature of the liquid inside the tank under 0°C (-5,5° C / - 7°C - 22.1/ 19.4 °F)
- The glycol is stirred by the agitator (F) and is recirculated by means of the recirculation pump (B).
- The chiller is composed of a compressor (H) that is the motor (engine) of the cooling system. When running, it is compressing a refrigerant (R134A) that is in a low-pressure gaseous state to a high pressure gas, like this the temperature rises to 90°C some 20 bar (C).
- The high pressure refrigerant gas, coming from the compressor, flows through the condenser (L) and becomes a liquid thanks to the fan (M) that draws air over the fins of condenser to dissipate the heat from the tubes and fins. As this occurs, the refrigerant gives off heat causing the temperature to drop to some 40°C
- Once the liquid refrigerant has traveled the length of the condenser, it is forced through the capillary tube (N) a tiny copper tube where it expands (from some 20 bar to ½ bar) The capillary tube is attached from the end of the condenser to the beginning of evaporator. When the liquid refrigerant comes out of the small capillary tube, it is injected into the larger tubes of the evaporator (O) causing a pressure drop. This pressure drop allows the refrigerant to expand back into a gaseous state. This change of state from liquid to gas absorbs heat, as a result the gas will be very cold.
- Because the evaporator is absorbing heat it is very cold to touch. The coldness causes any humidity in the air to freeze on the evaporator as ice.
- The gaseous refrigerant travels through the evaporator tubes down to the compressor to begin the circulation process again
- The transformer **OPTIONAL (TR)** is used to for led illumination of the dispensing unit (C)

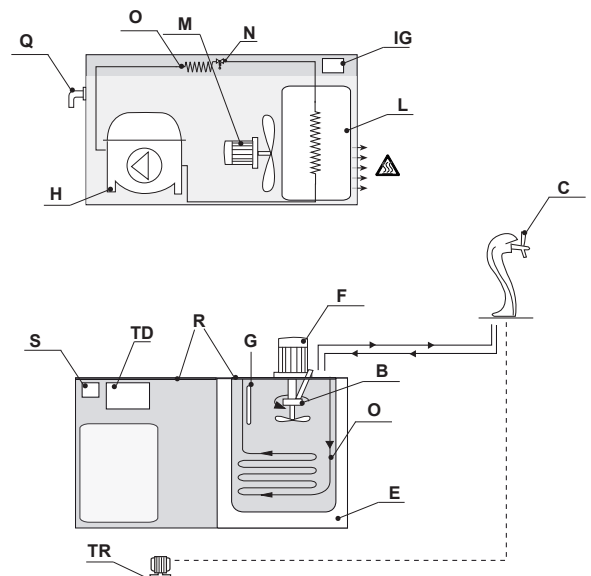

TECHNICAL SPECIFICATION

The machine external body is made of sheet metal and it is equipped with:

- *Agitator (F)* motor housing the *recirculation pump (B)* on the stem;
- *Removable panel (R)* for water loading and topping up;
- *Master switch (IG)*, *digital thermostat (TD)*, and plug (**S**)



Identifying machinery and manufacturer

The CE plate is placed in the position shown in the picture.

The nameplates mounted on the side of the machinery **MUST NOT**

be removed, damaged, soiled, hidden, etc. and must be cleaned regularly.

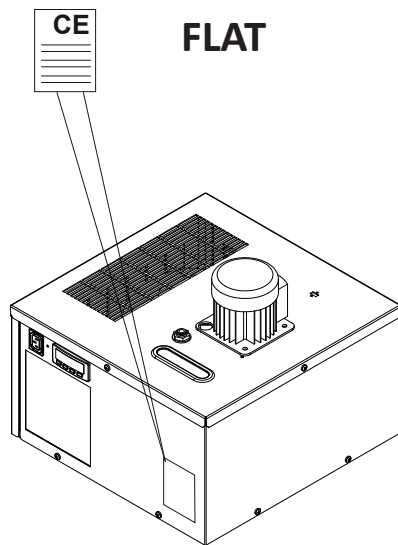

FLAT

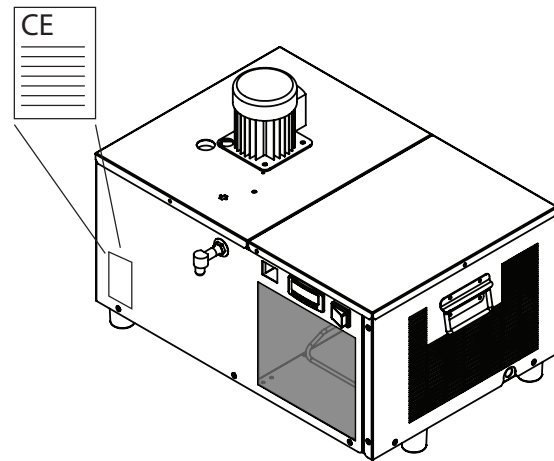

SUPER FLAT

	FLAT	SUPER FLAT
Power	1/6 hp	1/3 hp
Type of coolant gas	R134A	R404A
Nominal Power -10°C +45°C	301W	893W
Tank Capacity	13 lt.	17 lt.
Supply voltage/frequency standard outfit	115V 60Hz 200 220V 50/60Hz	115V 60Hz 200 220V 50/60Hz
Ice bank	4 Kg.	7 kg.
Recirculation pump	4/12 Ø50 mm	8/10 Ø37.5 mm
Allowable max. relative humidity	80%	80%
Weight (loadless static weight)	23 Kg.	42 Kg.

DIGITAL THERMOSTAT: INSTRUCTIONS

REV10042014

FRONT PANEL DESCRIPTION



KEYS DESCRIPTION

1. Key **P** : Used for setting the Set point and for programming the function parameters.
2. Key / Aux: Used for selecting the parameters and for decreasing the values to be set.
3. Key / : Used for selecting the parameters and for increasing the value to be set. Also used for activating manual defrost.
4. Key **U** : Used for visualizing the read temperatures.

LED INDICATORS

5. Led OUT: Indicates the compressor or temperature device output status. Led on= (ON), Led off = (OFF), Led blinking = (INHIBITED)
6. Led DEF: Indicates defrost status. Led on= DEFROSTING IN PROGRESS. Led blinking= DRIPPING.
7. Led FAN: Indicates fan status. Led on = (ON), Led off = (OFF) Led blinking = DELAYED AFTER DEFROSTING.
8. Led AUX: Indicates AUX output status. Led on = (ON), Led off = (OFF), Led blinking = (INHIBITED).

9. Led AL: Indicat the alarm status. Led on = (ON), Led off = (OFF), Led blinking = (SILENCED or MEMORIZED).

10. Led SET: Indicates access to programming mode and programming level of parameters. It also indicates standby status.

11. **Led -** : when (ON), it indicates that a low temperature alarm is in progress. When (BLINKING), it indicates that a low temperature alarm has been memorized.

12. **Led OK**: Indicates that no alarms are in progress

13. **Led +**: when (ON), it indicates that a high temperature alarm is in progress. When (BLINKING), it indicates that a high temperature alarm has been memorized.

SETTING THE SET POINT

Press **P** and release it and SP1 or SP2 will be visualized on display depending on the active set.

Use and to modify.

Press **P** to exit the set mode or press no key for 15 seconds.

SETTING CONFIGURATION PARAMETERS:

Switch on the cooler and make sure no procedure is running. To access function parameters;

TO SELECT A PARAMETER GROUP

Keep **P** pressed for about 5 seconds, after which the Led SET comes on and SP is visualized on display.

Press and to select the parameters group to be modified.

Press **P** and the code that identifies the parameter in the selected group will be visualized.

SETTING CONFIGURATION PARAMETERS:

TO SELECT A PARAMETER

Using and to select the desired parameter.

TO MODIFY A PARAMETER



When the display shows the parameter you would like to modify

Press **P** to memorize new value and display will only show the abbreviation of the selected parameter.



DIGITAL THERMOSTAT: INSTRUCTIONS

SETTING CONFIGURATION PARAMETERS:

TO MODIFY OTHER PARAMETERS

Use  and  to select and modify other parameters, and repeat steps as earlier described.

TO QUIT THE PROCEDURE

Keep  and  pressed until programming mode is exited or leave no key pressed for about 20 seconds.

THERMOSTAT PROGRAMABLE PARAMETERS

PARAMETER GROUPS DESCRIPTION

SP	PARAMETERS RELATING TO SET POINT
InP	PARAMETERS RELATING TO MEASURING INPUTS
rEG	PARAMETERS RELATING TO TEMPERATURE CONTROL
dEF	PARAMETERS RELATING TO DEFROSTING CONTROL
FAn	PARAMETERS RELATING TO EVAPORATOR FAN CONTROL
PrC	PARAMETERS RELATING TO COMPRESSOR PROTECTION AND POWER ON DELAY
AL	PARAMETERS RELATING TO ALARM CONTROL
dIn	PARAMETERS RELATING TO DIGITAL INPUT
AuS	PARAMETERS RELATING TO AUXILIARY OUTPUT
Out	PARAMETERS RELATING TO CONFIGURATION OF OUTPUTS
PAn	PARAMETERS RELATING TO CONFIGURATION OF THE KEY BOARD

PARAMETER	DESCRIPTION	ICE CUBE	MINI TWIN GLYCOL	MEDIUM TWIN GLYCOL	TWIN GLYCOL	SUPREME GLYCOL	COLDER	FLAT COLDER
SP1	Set Point 1	ON DEMAND	-3.3°C 26°F	-3.3°C 26°F	-3.3°C 26°F	-3.3°C 26°F	-5°C 23°F	-5°C 23°F
SEnS	Probes Type	NTC	NTC	NTC	NTC	NTC	NTC	NTC
Pr2 (1)	Pr2 Probe presence evaporator	OFF	OFF	OFF	OFF	OFF	OFF	OFF
HSEt	Differential	0.1	2	2	2	2	2.5	2.5
dEFE	Max. Length Of Defrost Cycle	0	0	0	0	0	0	0
dLO	Defrost Display Lock	OFF	OFF	OFF	OFF	OFF	OFF	OFF
PSC	Type Of Compressor	1	1	1	1	1	1	1
PtC	Compressor Protection Time	OFF	OFF	OFF	OFF	OFF	OFF	OFF

SWITCH POWER SUPPLY OFF & ON AFTER PARAMETER MODIFICATIONS.

SYMBOLS AND SIGNS

On the manual or in some cases on the equipment, tags, symbols or icons are used to indicate an obligation, a danger or a prohibition.

Obligation signs

- The document must be consulted, kept safe for future use and must neither be manhandled nor allowed to deteriorate in any way.



- Operations that require qualified and authorised personnel.



- Obligation to wear personal protective device provided by the employer (for example leather gloves) when performing certain tasks.



- Obligation to switch off the equipment before performing operations such as installation, cleaning, filling, maintenance etc....; unplug the machine



- Obligation to dispose both electric and electronic waste..



Danger signs

- Operations or situations in which personnel must exercise extreme caution: general hazard or hazardous voltage.



- Zones subject to low or high temperatures;
- Condensation or product leaks which can cause slipping or injuries.



- Hazard from electromagnetic interference or exhalation of highly inflammable vapours. Possible risk of deflagration.



Prohibition signs

- Indicates that access to a zone is prohibited or that an action is prohibited.



ACCIDENT PREVENTION AND RESIDUAL RISKS

REV10042014

• Although this equipment has been manufactured under the strictest safety regulations, however for obvious reasons it is not possible to foresee all the installations and environments in which this equipment will be installed. Therefore it is pertinent that customer should inform the manufacturer of peculiar installation conditions.

• The instructions set out in this manual do not replace the safety instructions and technical data on installation and operation of the equipment. It neither replaces common sense nor the safety regulations enforced in the country of installation.



• Operators must be given correct information. They must therefore read and follow the technical information set out in the manual and in the attached documentation. Carefully keep the technical documentation accompanying the equipment.

• VINSERVICE will not be held liable if installation instructions are not followed.

• Do not use the equipment if any operating fault occurs.

• The equipment has been designed under strictest energy saving regulations enforced in the manufacturing country therefore customer should avoid unnecessary energy waste.

• The equipment must not be installed outdoors or in adverse environmental conditions (sun, rain, snow, wind, high humidity, etc.) Also make sure that there is no electromagnetic interference. .

• Equipment has not been designed to operate in environments in which there is a danger of fire or explosions.

• *It is absolutely forbidden to tamper and/or inhibit or modify the safety devices.*

• The removal panel (R) can only be removed for installation, filling or maintenance operations only after unplugging the power cord. After such operations, the screws should be replaced.

• The warning signs must be kept legible and clean.

• *When the equipment is off or it has just been turned off, some parts might be over heated (agitator motor (D) or condenser air grating (H), thus the operators must pay attention when touching the equipment.*

• In case of fire, make use of carbon dioxide extinguishers and automatic suction systems to fight against fire in closed environments. Pay attention to flammable beverages.

Some models are supplied equipped with supports (B); in this case pay attention not to abandon the machine on inclined planes, which might cause dangerous situations.



• Cleaning and maintenance operations must be carried out when the machine is off after 5 minutes of unplugging the power cord.



- Personnel must NOT go anywhere near the equipment on bare feet or with wet hands. Personnel must also make use of suitable personal protection device used accordingly. Beverage leaks may cause slippage.

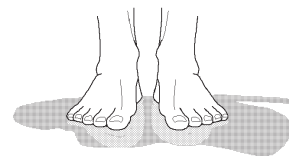
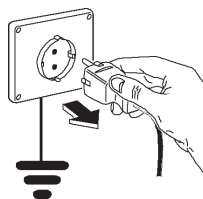

• Maintenance personnel must report any fault or deterioration due to wear or aging so that safety conditions can be promptly restored..

• Do not carry out makeshift repairs. Only manufacturer-approved spare parts must be used for the repairs and installed accordingly. Components must then be reassembled in the original position and condition.

• Cleaning of the equipment should be done with suitable devices and detergents that will not cause it any damage. The use of water jets for equipment cleaning or washing is strictly prohibited. Food circuits must be washed or cleaned with suitable non toxic products.



- *The installation, removal and/or reinstallation in other place and extraordinary maintenance operations must be done only by specialized personnel in compliance with the instructions outlined within this manual.*

Proper illumination of equipment installation location is advised in order to guarantee that all necessary operations are carried out in safe conditions.



- *Although VINSERVICE has removed sharp edges where possible, however the use of personal protective device e.g. leather gloves is recommended when handling: sheet metal, condenser fins (H), self-threading screws, etc...*

• The single equipment's output sound level (Noise) when operating at full capacity and correct maintenance is inferior to 70 dBA thus absolutely harmless to the operator. Whenever the noise threshold is exceeded due to different and unpredictable installation cases, ask for the intervention of a specialized technician.

• Handling and/or lifting of heavy objects (more than 30Kg) must be carried out by means of suitable lifting devices.

LIFTING AND TRANSPORT

- The equipment is usually shipped in a cardboard box packaging, adequately protected on all its edges. The packaging in its dry and integral state is self-supporting and sturdy enough for machine lifting and handling. If packaging is in a wet state, pay attention while lifting and make sure lifting bands are placed in the centre.
- Stacking of equipment over another is only allowed when packaging is in its integral and dry state.
- Equipment should be lifted one at a time.
- The lifting device (ropes, polyester belts, chains) must be designed to bear the weight of the machines: the opening angle must be the same as or less than 50°-60° in order to avoid crashing or damaging the packaging and/or the bodywork sheet metal.

• *During handling, check that the weight of the loads is correctly distributed on the ropes and do not make sudden movements that could create dangerous oscillations.*



• Remember that packing elements (wood, nails, paper, cellophane, metal points, adhesive tape, straps, cords, etc) may cut and/or cause injury unless they are handled with care. They must be removed with appropriate instruments and must be kept out of the reach of irresponsible persons (e.g. children). These rules also apply to the instruments used in removing the packing (scissors, hammers, pliers, knives, etc). The packing must also be eliminated and disposed of in accordance with the regulations in force in the country of installation

-  When opening the packing, check the machine for damage and check that no machine parts or accessories are missing.
- If you detect faults or deterioration, suspend operations immediately and contact the carrier or shipper and also notify **VINSERVICE** promptly.

The equipment must be transported, on the road in particular, by appropriate vehicles in the appropriate manner and parts must be protected from shock, humidity, vibrations, etc.

- The equipment must be transported in a vertical position, making reference to the symbols and writing on the packaging.
- Some models are delivered equipped with *support (B)*; in this case pay attention not to abandon the machine on inclined planes, which might cause dangerous situations.

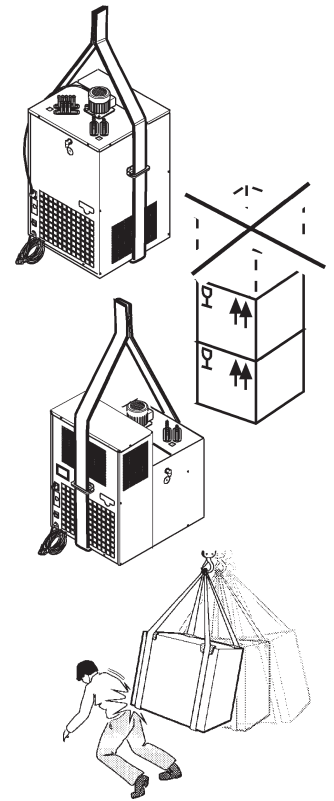

INSTALLATION



The chiller operation is completely automatic and does not require any particular intervention of the operator.

- First of all make sure the no leaks are present in the system and carry out a periodical control, as the chiller can be left always running.
- After making sure that all previously described conditions are present (water and electrical connections, tank filling, etc...), power on the machine by means of the chiller *master switch (IG)*; the integrated warning light lights up.
- During power on the *fan (M)*, the *agitator (F)* and the *compressor (H)* start up; after about 2-3 hours (according to the model and the machine capacity), the compressor and the fan stop, as will reach the set temperature, whereas the agitator keeps on running to stir water and ease the heat exchange.
- The *probe (G)*, positioned in the water, reads the temperature and controls the cooling system switching on and off.
- During operation, the *recirculation pump (B)* allows the cooling of the *distributor (C)*.
- The cooling capacity is automatically adjusted by means of the *digital thermostat (TD)* that controls the temperature inside the tank and activates the compressor.
- On request an *transformer OPTIONAL (TR)* can be installed.

Digital thermostat (TD)

The *mechanical thermostat (TM)* can be adjusted by means of a screw-driver. The screw can be positioned as follows:

- **Winter position:** adjust the screw from position 1 to 6 according to the room temperature; the lowest position (1) is recommended for very low room temperatures (3° ÷ 4°C), the subsequent positions (from 2 to 6) can be adjusted in steps up to about 10°C.
- **Summer position:** bring the screw to ICE BANK to get an *ice bank* thickness of 20 ÷ 40 mm around the *evaporator (O)*

Transformer (TR) OPTIONAL

The *transformer (TR)* allows feeding low voltage to the LEDs and neon lights that light up the plug or the *distributor (C)*.



- *In case of operation problems, refer to the chapter TROUBLESHOOTING, but do not carry out unknown interventions and apply to specialized personnel.*



N.B. Control and maintenance operations must be carried out when the machine is stationary and with the power supply disconnected, pulling out the plug. Any operation excluded from those started below must be carried out by specialized and authorized personnel.

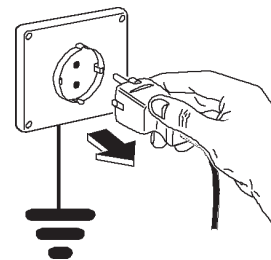

TROUBLESHOOTING		
Detected inconvenience	Possible cause	Controls and remedies
<ul style="list-style-type: none"> The chiller does not work (the master switch (IG) warning light does not turn on) 	<ul style="list-style-type: none"> Lack of current 	<ul style="list-style-type: none"> Make sure the machine was plugged in properly Make sure there is no disconnected wire and check the electric system
<ul style="list-style-type: none"> The machine does not cool (the fan (M), the agitator (F) and the compressor (H) do work) 	<ul style="list-style-type: none"> Be low on refrigerant 	<ul style="list-style-type: none"> Check the refrigerating circuit pressure make sure there is no leak and reload with refrigerant
<ul style="list-style-type: none"> The refrigerating unit works, but the agitator (F) is at a standstill 	<ul style="list-style-type: none"> Failure of agitator motor or lack of current 	<ul style="list-style-type: none"> Make sure the machine was plugged in properly Check the electric system Replace the agitator
<ul style="list-style-type: none"> The machine does not cool (the fan (M) and the compressor (H) are at a standstill, but the agitator (F) keeps on running) 	<ul style="list-style-type: none"> Malfunctioning of thermostat 	<ul style="list-style-type: none"> Check the thermostat electrical connections Replace the thermostat and the probe
<ul style="list-style-type: none"> The machine does not cool (the compressor (H) is at a standstill, but the fan (M) and the agitator (F) keep on running) 	<ul style="list-style-type: none"> Lack of current to the compressor The compressor broke down 	<ul style="list-style-type: none"> Check connections and electric system Check clixon and relays Replace the compressor
<ul style="list-style-type: none"> The chiller never stops 	<ul style="list-style-type: none"> Failure of thermostat 	<ul style="list-style-type: none"> Replace thermostat Replace probe
<ul style="list-style-type: none"> The machine does not cool (the fan (M) is at a standstill, but the compressor (H) and the agitator (F) keep on running) 	<ul style="list-style-type: none"> Lack of current to the fan motor The fan motor broke down 	<ul style="list-style-type: none"> Check connections and electric system Replace the fan motor
<ul style="list-style-type: none"> The agitator pump (F-B) motor is noisy 	<ul style="list-style-type: none"> Broken-down motor bearings Worn-out pump bushings 	<ul style="list-style-type: none"> Replace the agitator motor Replace the pump

MAINTENANCE



Routine maintenance

Routine maintenance can be carried out by common specialized personnel in compliance with the above-mentioned rules.

- **Every day** check for leaks.
- **Every six months** clean the *condenser (L)* fins with brushes and/or jets of compressed air. Pay attention not to bend the fins. They are sharp, always use leather gauntlets.
- **Every month** check that the *overflow (Q)* exhaust tube is not clogged or dirt or crashed.
- **Every month** clean the machine sucking in the dust, filaments, paper, which might overheat motors or cause faulty operation.



Extraordinary maintenance

Extraordinary maintenance must be performed by specialized personnel.

- **Every year** clean the *tank (E)*. To this purpose, DO NOT use pointed objects which might make a hole into the tubes or the tank. Do not use abrasive products. A good cleaning improves the chiller performance. Fill the tank again possibly with non calcareous water.

Storing, dismantling and disposal

- If the machine remains unused for long periods, disconnect the unplug it and hydraulic and electric *systems*; empty and clean it; sanitize and wash the coils. Let them dry and plug them; then store the machine after packing with the original *packaging*, if available, in a dry place. Do not stack more machine components without the original *packaging*.
- **VINSERVICE** accepts no responsibility for the disposal of the *packaging* or parts of the machine or products used to run the machine: *coolant gas*, compressor or under pressure containers, condensers, etc. The Customer is therefore personally responsible for the disposal of such substances, which are potentially harmful for the environment.



Remember that it is an electrical equipment, whose components must be disposed according to laws in force in the of installation country.

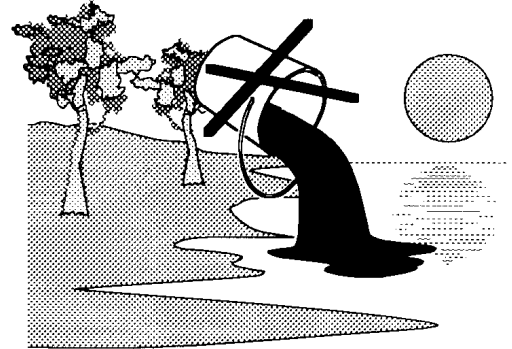

Technical drawing super flat

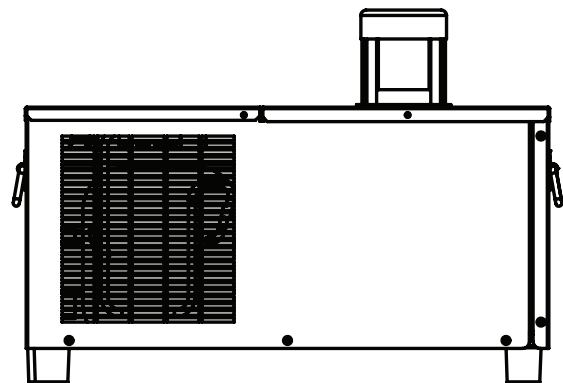
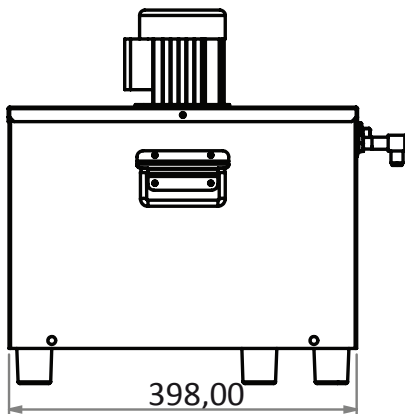
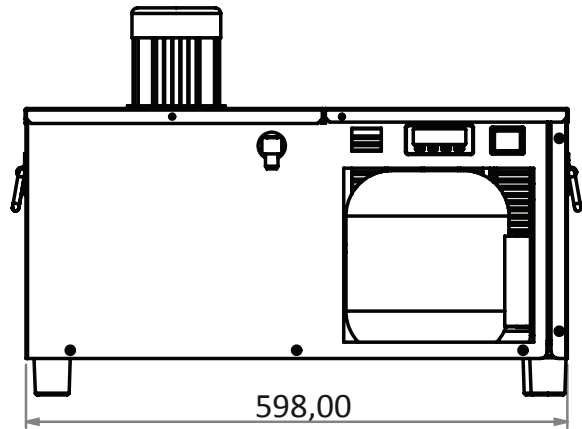
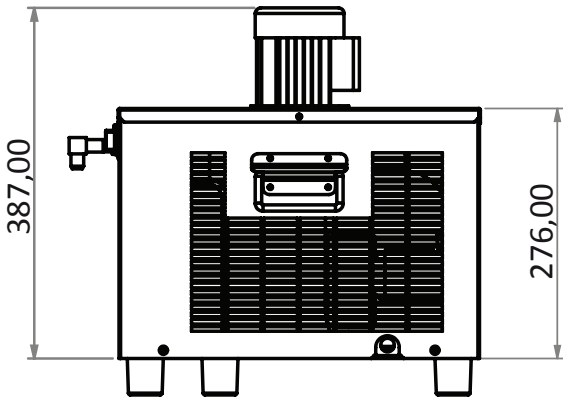
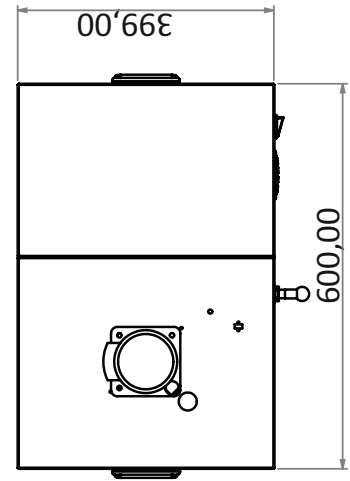
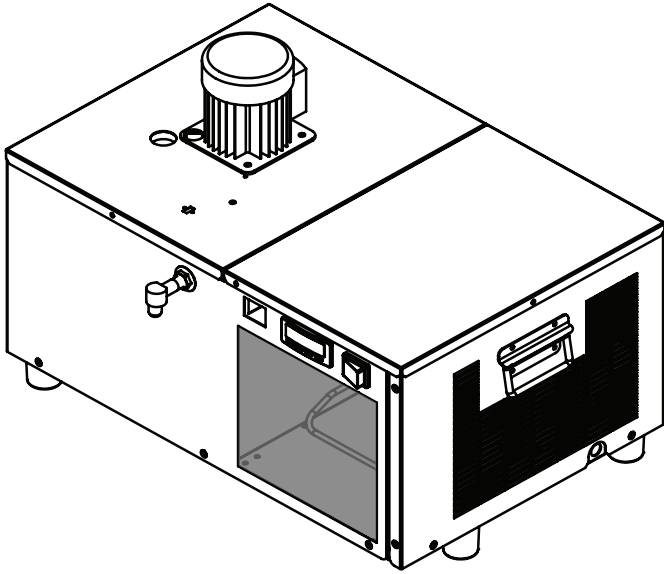

Technical drawing

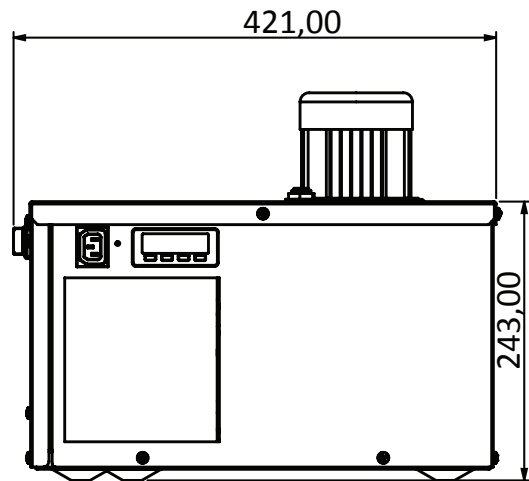
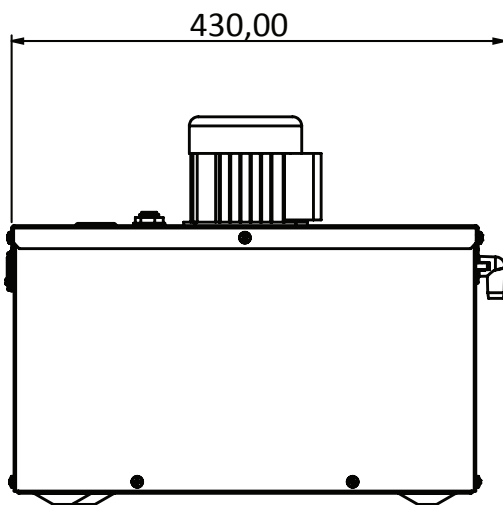
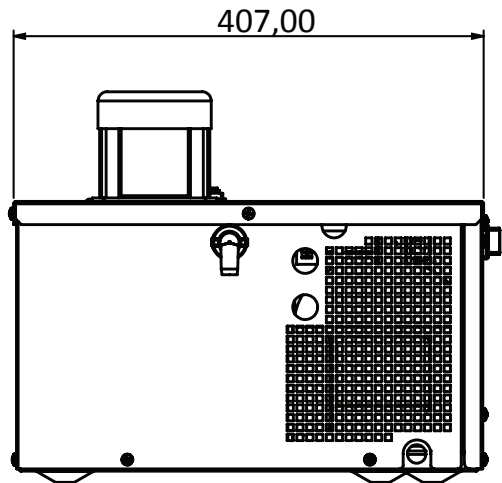
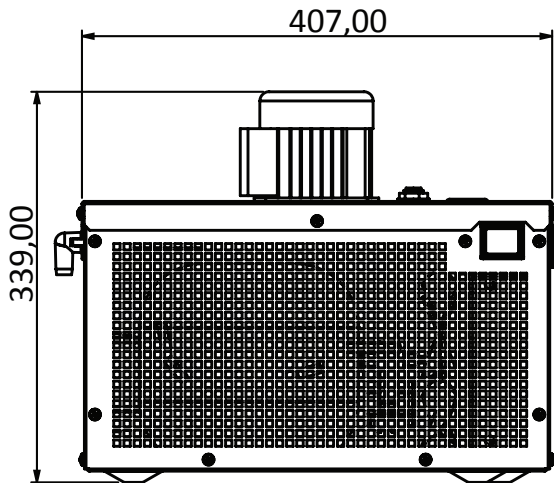
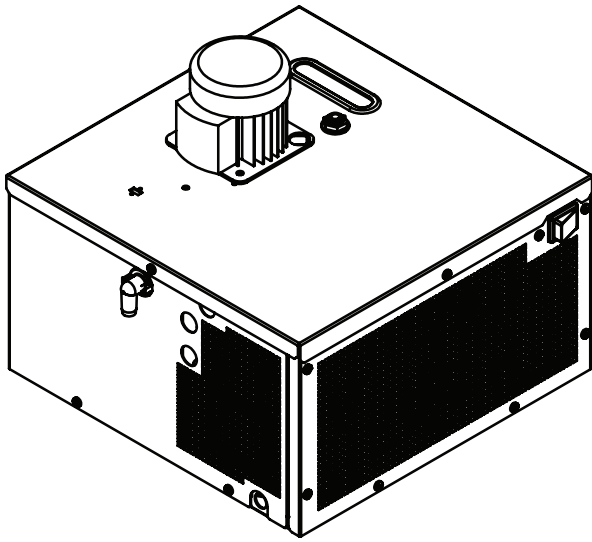

DECLARATION OF CONFORMITY " C E "

ACCORDING TO MACHINE DIRECTIVES :

"Machines" 2006/42/CE
"Low tension" 2006/95 CE
"EMC" 2004/108 CE

VIN SERVICE S.R.L.-VIA G. FALCONE 26/34, 24050 ZANICA (BG)

Declares under its own responsibility that:

FLAT - SUPER FLAT

Have been designed and built in compliance with the safety requirements requested by the "CE" marking regulations

Zanica, date: 02/05/2011

THE SOLICITOR
RICCARDO GUADALUPI GRADUATE OENOLOGIST

